

# LIGHT

---



## TEACHER'S THOUGHTS

Imagine complete darkness. If you close your eyes, you still are not experiencing complete darkness. However, if you have ever gone into a cave and the lights have been shut off, you know what complete darkness is. You can put your hand in front of your face and not see it. Complete darkness.

What is a world without Christ? Darkness. What is a life without Christ? Darkness. But as He comes into a life, the life is illuminated with His light. The darkness is chased away by the new light.

On the first day of creation, God spoke and light appeared. The sun wasn't formed yet so the light was a source other than the sun. Scientists say that there is a light in the universe that does not have the sun or stars as its source. We need not only physical life, but also spiritual life. Without Christ, the Light of the World, we would still be in spiritual darkness. John 1:4 says, "In Him was life and that life was the light of men." Once the light penetrates the darkness, our world will never be the same.

"You are worthy, O Lord our God, to receive glory and honor and power. For you created everything and it is for your pleasure that they exist and were created."

Revelation 4:11 (NLT)

## CREATION STORY

Day one  
Creation of light

## SPIRITUAL POINT

God sent Jesus  
to drive away the  
darkness of sin.

## BIBLE VERSE

"In Him was life,  
and that life was the  
light of men."  
John 1:4

## OVERVIEW

God physically  
created light that drove  
away the darkness.  
God sent Jesus, the  
light, to drive away the  
darkness of sin.

# LESSON 1

## Creation Mural

---



### BLACK/WHITE CONTRAST

Supplies: White piece of material, black piece of material, (use shower curtains, plastic tablecloths, paper)

Hang the black and white material side by side.

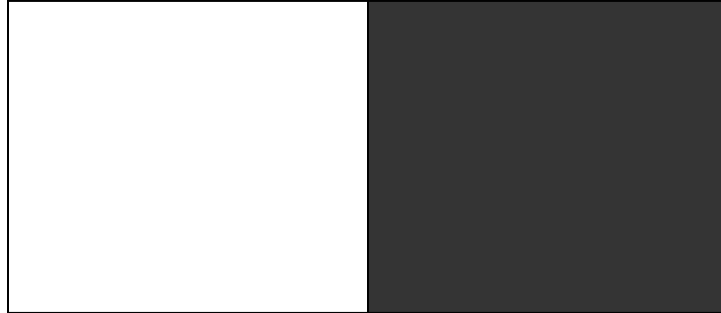

## Lab Wear

---

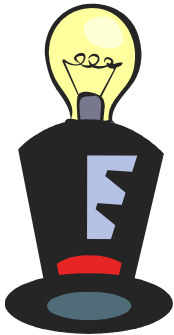

### LIGHT BULB HATS

Supplies: Plastic top hat, light bulb

Instructions: Cut a hole in the top of the hat the size of the bottom of the light bulb. Insert the light bulb into the hat, fitting it just far enough into the hat to be secure.

### FLASHY LAB GLASSES

Supplies: Lab glasses, battery operated flashing lights

Instructions: Glue the flashing lights around the rim of the lab glasses. Make sure you turn off the flashers during any experiments that need darkness.

# Sizzle and Fizzle

(PP)

Supplies: Fluorescent eye balls (see instructions), black lights, flash pads/paper, glass pie pan, lighter

Preparation: Place black lights so they illuminate the eye balls. Allot time to experiment with proper placement of the lighting. Put the flash paper in a flame proof glass pie pan, lighter

Note: For a less complicated skit, use voices in the dark without the eyeballs. The flash paper is optional.

**Instructions for fluorescent eye balls:**

Supplies: Six Styrofoam balls, white, red, black and yellow fluorescent paint, four dowel rods. Cut one dowel rod into three equal portions. (You will be making three sets of eye balls.) Paint two sets of eye balls white with a black iris. Paint one set of eye balls yellow with a red iris and red “bloodshot” lines. Glue a long dowel rod to the center of each of the small “cut” dowel rod creating a handle. Place an eyeball on each end of the small dowel rod.

(Turn out the lights.)

Fizzle: **Hey Sizzle.** (Moment of quiet) **Pssst. Sizzle.** (Another moment of quiet)

Sizzle: **Fizzle. Hey, Fizzle.** (Moment of quiet.) **Sure is dark in here. Wish I had a flashlight. I’d even take a lightning bug at the moment. Where is my lab partner? Maybe he knows where the light switch is. Fizzle? Fizzle, where are you?**

Fizzle: **Over here. I’m looking for the light switch. I think I’ve found it.**

Sizzle: **Be careful. You know you can’t mess around in a lab. There are very important things in the lab. Things that will explode and things that will cause commotion. You know what Dr. Beaker always tells us: “Safety first.”**

Fizzle: **How can I be safe when I can’t even see? I’m just going to flip this switch and we’ll see what happens.**

Sizzle: **No, don’t do it. We need to find a flashlight and then see what the switch is for.**

Fizzle: **Don’t worry. It has to turn on a light. What else are switches for?**

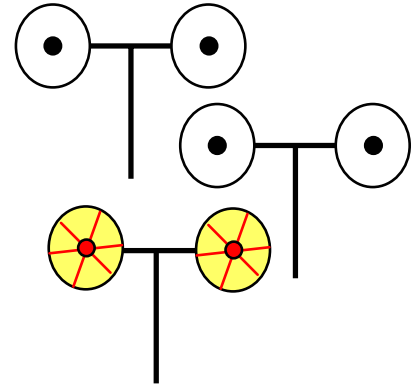

**TIP**  
You will need an extra person to assist Fizzle and Sizzle to ignite the flash paper.

# LESSON 1

## Helper!

(PP) (Explosion sound. Hold the pie plate up behind the puppet curtain. Light the flash paper when the explosion sound occurs.)

Sizzle: **Well, it could be for...**(explosion sound) (Hold the pie plate up behind the puppet curtain. Light the flash paper)

Sizzle: **That.** (Pause) **Fizzle, are you ok? Fizzle. Fizzle!**

Fizzle: (Fizzle reappears with blood shot eyes.) **Yeah. I'm ok. I think. I mean, I'm ok if you don't count every broken bone in my body.**

Sizzle: **Oh, Fizzle. When will you ever learn safety in the lab?**

## (PP) Puppet Song

---

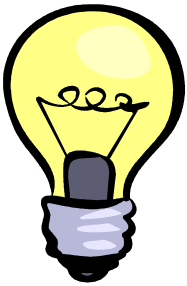

“I Wanna Be A Light Bulb” from Top Novelty Songs by One Way Street, 2000.

Song suggestions: Use black lights. If you do not have light bulb puppets (available from One Way Street), make light bulbs out of foam core board and paint them with fluorescent paint or cover them with fluorescent paper.

“The Light of the World” from Seeds of Faith by Authentic Music, 2001.  
“I am the Light of the World” from God Prints 2 by EMI, 2002.

## (PP) Dr. Beaker

---



Supplies: Flashlight

Welcome to my laboratory. I am Dr. Beaker. My work here in the lab is extremely important. I am researching the creation of the universe. It has been communicated to me that you will be joining me in my study. Splendid! I do need to tell you some safety rules. When in the lab, you never taste anything. You never touch anything without permission. You handle all experiments with great care. And you wear safety glasses. Does everyone understand the rules? (Wait for the children to say yes.) Good. You are doing better than my lab assistants Fizzle and Sizzle. There was quite the explosion earlier because Fizzle did not follow the rules. (Shakes his head.) I am quite concerned with that lab assistant. Good thing I have Sizzle around to stop him from making too much of a mess.

Let us move on with today's study of creation. We are going to talk about light. The Bible tells us that in the beginning, there was nothing. Just blackness. So the first thing that God created was light.

# Helper!

(Talks to teacher) Would you be so kind as to hold a flashlight for me?

Light follows rules. Which is more than I can say for Fizzle! Anyway, light always goes in a straight line. (Teacher shows flashlight and how the beam always is straight.) Now if it hits something then it will bend - but as long as nothing is in the way, it will be straight. You can always count on it.

There are other things about light you can always count on. You see when God made the universe, He also made rules for the way the universe behaves. Those rules are constant; you can depend on them just like you can depend on God. My job as a scientist is to learn about and describe the design that the Creator, God, made. As my assistant scientists, your jobs are to do the same thing.

I am now going to go and prepare for my experiments. Pay close attention today as you learn about the first day of creation and about light. (Dr. Beaker exits.)

## Bible Story

---

(pp)

Supplies: Clear container, pitcher of water, dry ice, light stick

**Many people have theories about how the universe began. Do you know what a theory is? It is an explanation that a scientist makes about how something works. However, it is not fact. It is just a guess.**

(pp)

**You may have learned about some of these theories in school. Some words you may have heard are Evolution or The Big Bang Theory. Or you might have heard about something called Intelligent Design Theory. Those are all big words and they are all ways that scientists have guessed how the world came to be.**

(pp)

**We are going to learn what the Bible says about how the world came to be. Everything in the Bible is true. It is God’s word. So, do you think what we are going to learn is a theory? (No, it is a fact.)**

(Hold up a Bible.) **Does anyone happen to know the book of the Bible that tells us how the world began? (Genesis.) The very first verse in the Bible tells us how it all began. Genesis 1:1 says that, “God created the Heavens and the Earth.”**

(pp)

**God is eternal. That means that He has always been and He always will be. That is really hard for our human minds to understand. Before everything was created, God was here. Sometimes when we say**

(pp)



# LESSON 1

**God, we think of God the Father. But, it was all three persons of God: God the Father, God the Son, Jesus, and God the Holy Spirit who created the world.**

**Today we are going to talk about what God created first. Let's read the Bible and see what it says:**

(Have the dry ice in a container in front of you)

**(pp) "First this: God created the Heavens and Earth--all you see, all you don't see. Earth was a soup of nothingness, a bottomless emptiness, and an inky blackness. God's Spirit brooded like a bird above the watery abyss."**

(Pour water over the dry ice.) **"God spoke: "Light!"** (Break the light stick and drop it into the dry ice.)

**"And light appeared. God saw that light was good and separated light from dark. God named the light day, He named the dark night. It was evening, it was morning--Day One."** Genesis 1:1-5 (TM)

**Have you ever been in complete darkness? One place where you can be in complete darkness is a cave. If you go into a cave and shut out your flashlight, it is so dark that you cannot see your hand in front of your face. That is what complete darkness means.**

**With God's first command, He brought light into the darkness.**

## **(pp) Life Application**

---

Supplies: Flash paper, lighter, nonflammable plate

**Today you have learned about God creating light.** (Turn out the lights.) **Watch what I am doing carefully.** (Place the flash paper on the plate and light it.) **Did you notice that for just a second, the darkness was driven away?** (Turn on lights.)

**When light comes into darkness, the darkness goes away. When Jesus came down to earth, he came to drive the darkness away. The Bible tells us that Jesus said, "I am the light of the world." God's word in John 1:4 also says that, "He was life and that life was the light of men."**

**(pp) The world has darkness in it because of sin. When Jesus came as the sacrifice for sin, it gave us a way to drive the darkness away from our lives. When we ask Jesus to forgive us, the darkness of our sins are gone forever. Only light remains.**



However, we need to make sure that we keep on shining His light. We do not want to be like the paper that lit for a brief second and then disappeared. We want to keep burning brighter and brighter for Him. For instance, a campfire keeps burning as long as you put more logs on it. The more logs you put on it, the bigger the fire gets.

(PP)

What will you be? Do you want to be a light for Jesus that just keeps getting brighter? Or do you want to burn out quickly? The choice is yours.

## Prayer

---

Have the children think about what kind of light they are. Do they even burn for Jesus? If they are a light for Jesus, do they burn out quickly? Or do they keep adding fuel to the fire by reading their Bibles and talking with Him everyday? Lead the children in prayer for whatever area they may need help with.

(PP)



## Dr. Beaker's Lab

---

Today we are going to do some experiments with light. Before we begin, let's remember the rules. You never taste anything in the lab. You never touch anything unless you are told to. I am going to do the experiments and ask for help when needed.

(PP)



### EXPERIMENT #1: DIFFERENT KINDS OF LIGHT

Supplies: Candle, lighter, flashlight, Christmas lights, lamp, light stick

Show the children each source of light one by one. Do not turn them on yet. **What do each one of these items have in common?** (They all supply light.)

Turn out all the lights. **Lets see how much light each one supplies.** Light the candle and hold it up. Break the light stick and show the light it puts out. Turn on the flashlight and shine it around on the children. Plug in the Christmas lights and then turn on the lamp. **Which one gives off the most light? If you were in the dark and needed to find something which source of light would you rather use?**

We have talked about Jesus being the light of the world. His followers should also shine with his light. As you become closer to Him, your light will shine brighter. You may start out as a light stick or a candle but as you grow spiritually you will end up burning bright like a lamp.

# LESSON 1

## **EXPERIMENT #2: BLOWING OUT THE LIGHT**

“Neither do people light a lamp and put it under a bowl. Instead they put it on its stand, and it gives light to everyone in the house.” Matthew 5:15

Supplies: Votive candle or tea light candle, lighter, large clear drinking glass, clear pie tin or plate, food coloring, water

Put the votive candle on the pie plate and add 1/2 inch of water to the pie plate. Put a few drops of food coloring into the water so the experiment is easier for the children to see. Light the candle, and then place the glass over the candle. The candle should extinguish pulling the water into the jar.

**What happened when I placed the glass over the candle?**

**In Matthew 5:15, it says “Neither do people light a lamp and put it under a bowl. Instead they put it on its stand and it gives light to everyone in the house.” When we are living for Jesus, we need to let our light shine. We should not try to hide our light from others but shine brightly for Jesus. In the same way, we can hide our light by acting in ways that are not Christ-like. When we do that, our light goes out just like the candle. What are some actions that are not Christ-like? (Talking back to parents, disrespecting teachers, watching bad television shows, using filthy language, and being unkind to brothers or sisters.)**

## **EXPERIMENT #3: FUN WITH TONIC WATER**

Supplies: Tonic water (must contain quinine), clear drinking glass or jar, black light, salt

Turn out all the lights and turn the black light on. The darker the room, the better the experiment works. Pour the tonic water into the clear glass under the black light. You should notice a blue/violet fluorescence coming from the tonic water. Add salt to the tonic water while the glass is still under the black light. When the salt is added, the fluorescence will dim.

**We talked about how our light should shine. Notice how the glass glowed in the dark. What happened when I added salt to the glass? The fluorescence began to dim. Do you think this happens in our life? When we add things to our life that should not be present, does our light begin to dim?**



**EXPERIMENT #4: DISSECT A LIGHT STICK.**

Supplies: Two light sticks, utility knife, clear drinking glass, safety glasses

**Caution:** The light stick contains a glass tube inside it. When cut open, it can shatter sending small pieces of glass flying. Be careful. Make sure you put on safety glasses and have any children that are close to the area wear glasses.



Hold up a light stick. **What will happen to this light stick when I bend it?** Ask a child to come up front and bend it for you. **Does anyone know why it glows?**

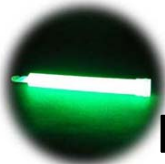

Light stick #1

**I am going to show you why the light stick glows. However, you need to understand that you are not to ever do this at home.**

Pick up the other light stick and tip the light stick so that the glass tube inside it slides to the bottom of the light stick. Wearing safety glasses, use a knife to cut through the light stick at the top. Make sure you do not cut into the glass tube. This is a delicate maneuver because squeezing too tightly on the light stick will result in the inner tube breaking. Pour the liquid into the clear glass, without allowing the glass tube to come out. (There will be only a few drops that will come out.)



Light stick #2

**Is this liquid glowing?** (It should not be.)

Pry the tube out of the stick. Show this to the children. Hold the tube over the glass. Break it very carefully, pointing the breaking point down toward the glass. Pour the contents into the glass and swirl the two liquids together.

**What is happening now?** (The liquid should be glowing. Turn out the light for the full effect.)

**What made the light stick glow?** (The glass tube inside it breaking.) **We cannot glow by ourselves. Just like the light stick must have the contents of the glass tube to glow, we need to have Jesus in our heart to glow**

**TIP**  
If you purchase the Kamp Kaboom Kit, there are two extra light sticks included for practicing before class

**EXPERIMENT #5: HUMAN POWERED FLUORESCENT LIGHT**

Supplies: Fluorescent light, balloon



# LESSON 1

**Difficult Level:** This experiment is often difficult to make work. The room must be completely dark in order to see the sparks of light. If you cannot make your room this dark, you should skip this experiment. Make the room completely dark. Hold the fluorescent bulb in one hand and the balloon in the other. Rub the balloon vigorously on your hair. Bring the balloon near the bulb and watch what happens. There should be a flicker of light. Move the balloon up and down the bulb without touching the bulb. The lights should “follow” the balloon.

**Did you see the flicker of light? Did the light last long? You had to look closely and pay attention or you missed the light. How do you think Jesus wants our light to shine? To continue shining brightly? Or to flicker and then go out?**

## **EXPERIMENT #6: WINTERGREEN CANDY**

**Supplies:** Wintergreen candy for each child, pliers

Turn off all the lights. The room needs to be as dark as possible. Put the wintergreen candy between the pliers and press down on the pliers. If you watch carefully, you can see a spark of light.

Divide the children into groups of two. Give out a piece of candy to each child. Have them put the candy in their mouths and with open mouths crunch down on it with their back teeth. They should be able to see sparks in their partner’s mouth.

Again, reiterate how our light should continue to shine and not flicker quickly.

# Scientist Story

---

## Johannes Kepler

When Johannes Kepler was five years old, his mother took him to the top of a hill. There the two of them viewed the bright path of a comet. Watching the comet was a big event in Kepler's life for comets do not occur in the sky very often. This was only the beginning of Johannes Kepler's fascination with the universe.

Johannes Kepler was a great scientist who lived almost 500 years ago in Germany. He worked with light and discovering special things about how light works. He is best known for figuring out how planets move around the sun. He worked hard to understand God's wonderful creation.

Kepler loved God. He believed that God created the world. Because God is an intelligent and orderly being, he believed that the universe must also be orderly. So, Kepler went about trying to find out how the universe worked. Kepler's favorite verse was Psalm 147:5, "Great is our Lord and mighty in power; His understanding has no limit." He knew that the great God that he served also made a great universe.

Kepler did not have an easy life. His childhood was hard. His father did not let him attend school, instead sending him to work to help make money. When Johannes was 16, his father died. Then, later in his life his wife died and so did three of his children. His mother was also falsely accused of being a witch.

Through all the hard things he faced, he never gave up on the true light of the world, Jesus. He said simply, "I am a Christian." In fact, early in life he thought he was to be a preacher. However, God opened other doors for him. At the end of his life he said that even though he intended to be a theologian, God was glorified in his study of science. For "the heavens declare the glory of God."





## TIP

Fluorescent Scratch Art Paper can be purchased from various craft and art stores.

## Craft Lab

---

### **IDEA 1: FLUORESCENT SCRATCH PAPER**

**Supplies:** Fluorescent scratch art paper, scratch tool (wooden skewer works well), black light

**Preparation:** Set up a black light in a darker part of the room or in a separate room. The room does not have to be completely dark for this to activity to work. Prepare an example of the craft to show the children.

With the scratch tool, have the children draw a picture of their favorite part of creation on the scratch paper. The scratch tool will scratch the top layer of black off the paper revealing a different color under the layer. When finished, take it to the dark area and shine the black light on it. The light will need to be held close to the paper for the children to see the picture glowing.

### **IDEA 2: CANDLE HOLDER**

**Supplies:** Votive holders or baby food jars, colored tissue paper, paintbrushes, glue, disposable containers for glue, tea light candles

**Preparation:** Pour the glue into the disposable container. Dilute the glue with water. Make a sample craft to show the children.

Cut the tissue paper into ½-inch to 1-inch squares. Some children may want to create a color pattern with a limited number of colors. Others may wish to randomly place the tissue on the glass. Paint an area of the glass with glue. Stick on the squares of tissue paper. To make the tissue paper lay down better, the children may need to paint a layer of glue over the tissue paper. Place a tea light candle inside the candleholder.

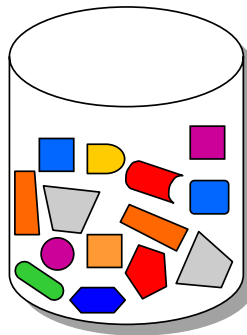

**IDEA 3: LAVA LIGHT**

Supplies: Empty plastic water bottle, food coloring, 1/3 cup vegetable oil, shaker filled with salt

Fill the water bottle with 3 inches of the water. Place a few drops of food coloring in the bottle. Swirl the bottle around a few times to mix the food coloring into the water. Add the oil and let the layers settle. Shake in salt while you count to five. The oil and salt should form a glob and sink to the bottom of the bottle, but after a short while the oil should float back to the top. Add salt again to watch the action repeat.

Note: The floating “globes” will not continue like a lava light. It is a one time occurrence each time salt is added to the oil.

# LESSON 1



## Memory Verse Lab

---

“In Him was life and that life was the light of men.”  
John 1:4

### **IDEA 1: FLUORESCENT WRITING**

Supplies: Liquid laundry detergent (dye free works best), paper, Q-tips® or paint brushes, black light

Dip Q-tips® in the detergent and write the verse on the paper. Allow the verse to dry. It does not have to be completely dry to work. Turn on the black light and hold the paper under the light. The words will glow under the light.

#### **TIP**

Black lights can be found at many Wal-Mart and home stores. You can buy a fixture with a fluorescent black light or a single bulb to place in any lamp.

### **IDEA 2: INVISIBLE WRITING**

Supplies: Bowl of lemon juice, Q-tips®, paper, lamp with a 100 watt light bulb

Write the words to the Bible verse on the paper with the Q-tip® dipped in lemon juice. Let the paper dry. Hold the verse up to the light to read the verse. The heat will cause the lemon juice to become visible.

Note: The writing becomes visible but not dramatically so.

### **IDEA 3: GLOW IN THE DARK WRITING**

Supplies: Glow in the dark pen or glow in the dark paint and paintbrush

Have the children write the verse on a piece of paper with a glow in the dark pen. You may also write the words with a paintbrush and glow in the dark paint. Expose the papers to light for a few minutes then turn out the lights. The verse should glow in the dark.

## Small Group Lab

---

### Snack Time

#### **OPTION 1: JELL-O®**

Supplies: Spoons, prepared Jell-O®, flashlights, clear plastic drinking glasses or cups

Spoon the Jell-O® into a cup. Pass the flashlights around and let the children shine the flashlight through the Jell-O®.

#### **OPTION 2: OREOS®**

Supplies: Oreo® cookies, paper plates

Give each child an Oreo®. Have the children pull their Oreos® apart. Review how God separated the light from the dark, comparing the white filling to the light and the cookie part to the dark.

#### **Discussion Questions**

Has anyone ever been in a cave and all the lights were shut off? What did it feel like?

Has anyone else ever been in a really dark place?

That darkness is like the darkness of sin. What does it feel like when you know you have sinned? Do you feel lonely?

Who can take away the darkness of sin and put light in your life?

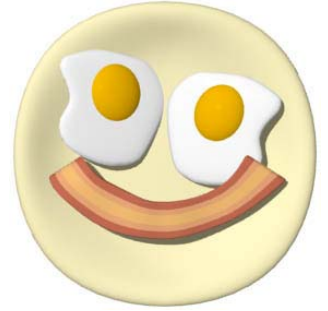

# LESSON 1



## Experiment Lab

---

Each of these experiments deal with light. The object of these experiments is to experience different characteristics of light. By doing so, children discover more about the wonderful creation that God made on the first day.

### **EXPERIMENT 1: SHADOW PORTRAIT**

Supplies: Butcher paper, pencils, flashlight, tape

Tape a piece of paper on the wall. Have someone stand in front of the paper. Shine the flashlight on the child. Have someone else trace the child's shadow.

### **EXPERIMENT 2: SHADOW PLAY**

Supplies: Flashlight, various action figures or odd shaped objects

Line the action figures up against a wall. Let the children experiment with the flashlights. Have them move the figures different distances from the wall to see what will happen to the shadows. They may also make shadow puppets using their hands. Let them get creative!

### **EXPERIMENT 3: THREE DIMENSION GLASSES**

Supplies: Cardstock, pattern for glasses (resource CD), clear transparency, permanent red marker, permanent green marker, tape, scissors, three-dimensional red-green picture (resource CD)

#### **NOTE**

The 3-D picture must be printed in color.



Trace the pattern for the glasses onto cardstock. Cut out the glasses. On the transparency, color an area the same size as the eye holes with the green marker. Color another area with the red marker. Cut out the colored pieces of transparency and tape them to the inside of the glasses. You have now created 3-D glasses. Put on the glasses and look at the 3-D picture.



**EXPERIMENT 4: COLORED LIGHT**

Supplies: Flashlights, different colors of cellophane or plastic wrap, rubber bands

Cut out six-inch squares of each color of cellophane. Place them on the end of the flashlight with the bulb. Secure the pieces of cellophane to the flashlight with a rubber band. Turn on the flashlights and point them toward a wall. Let the children experiment with shining different colors on the same spot on the wall.



## Game Lab

---

### **OPTION 1: DARK AND LIGHT**

Supplies: Parachute or bed sheet, two colors of foam balls or ping-pong balls (rolled up socks work for this also)

Place the foam balls in the middle of the parachute. Have the children hold onto the edge of the parachute. Start shaking the parachute, trying to separate the balls. This is a reminder of how God separated the light from the dark on day one of creation.

### **OPTION 2: BLIND MAN'S BLUFF**

Supplies: Blindfold

Have the children form a circle. Blindfold one child and place him/her in the middle. The children call the blindfolded child's name while he/she tries to reach out and catch someone. The children must not move out of the circle. Once the blindfolded child has caught someone, he/she trades places with that child.

### **OPTION 3: BALLOON SEPARATING**

Supplies: 15-30 white or yellow balloons, 15-30 black balloons, string

Preparation: Tie a string across the middle of a room. Blow up all the balloons and mix them up.

Place 15 balloons on each side of the string. Divide the children into two teams and assign each team to a side of the string. On "go", the children try to get only one color of balloon on their side of the string. They throw or bat the wrong color to the other side of the string. The first team to successfully have all the balloons the same color wins.

**OPTION 4: ORDER OUT OF CHAOS**

Supplies: Blindfold for each child

Divide the group of children into two-three teams. Blindfold each child. Within each group, give each child a number. The team members must line up in numerical order. The first team to accomplish this wins. For older children, do not allow them to use verbal communication or allow only noises but no words.



# PLANNING SHEET

**Kamp Kaboom Staff**

---

---

**Mural & Lab Wear**

---

- Get:**
- white piece of material
  - black piece of material (shower curtains, plastic tablecloths, paper)
  - plastic top hat  light bulb  \*lab glasses  \*lab coat
  - battery operated flashing lights

**PowerPoint & Sound**

---

**Actors/Puppeteers**

---

**Drama/Puppet Props**

---

- Get:**
- glow in the dark eye balls  black lights  \*flash pads/paper
  - glass pie pan  lighter  flashlight

**Bible Story Staff**

---

- Get:**
- clear container  pitcher of water  dry ice  \*light stick

**Life Application Staff:**

---

- Get:**
- flash paper  lighter  nonflammable plate

**Dr. Beaker's Lab Staff:**

---

- Get: Experiment 1**
- \*candle  lighter  flashlight  Christmas lights  lamp  \*light stick

- Experiment 2**
- \*votive or tea light candle  lighter  large clear drinking glass
  - clear pie tin or plate  food coloring  water

- Experiment 3**
- tonic water (must contain quinine)  clear drinking glass or jar
  - black light  salt

- Experiment 4**
- \*two light sticks  utility knife  clear drinking glass  \*safety glasses

- Experiment 5**
- fluorescent light  \*balloon

- Experiment 6**
- wintergreen candy for each child  pliers

\*= Available in the optional Kamp Kaboom kit

**Scientist Story Staff:****Craft Staff:**

- Get: Idea 1** fluorescent scratch paper scratch tool (wooden skewer works well)  
black light
- Idea 2** votive holders or baby food jars tissue paper paintbrushes glue  
disposable containers for glue tea light candles
- Idea 3** empty plastic water bottles food coloring vegetable oil  
shaker filled with salt

**Memory Verse Staff:**

- Get: Idea 1** liquid laundry detergent (dye free works best) paper  
Q-tips® or paint brushes black light
- Idea 2** bowl of lemon juice Q-tips® paper lamp with a 100 watt bulb
- Idea 3** glow in the dark pen or glow in the dark paint paintbrush

**Small Group Staff:**

- Get: Option 1** spoons prepared Jell-O® flashlights  
clear plastic drinking glasses or cups
- Option 2** Oreo® cookies paper plates

**Lab Experiment Staff:**

- Get: Experiment 1** butcher paper pencils flashlight tape
- Experiment 2** flashlight various action figures or odd shaped objects  
cardstock pattern for 3-D glasses (reference CD) clear transparency
- Experiment 3** permanent red marker permanent green marker tape scissors  
three-dimensional red-green picture (reference CD must be a color copy)
- Experiment 4** flashlight different colors of cellophane or plastic wrap rubber bands

**Games Staff:**

- Get: Option 1** parachute or bed sheet two colors of foam balls or ping-pong balls  
(rolled up socks work for this also)
- Option 2** blindfold
- Option 3** 15-30 white or yellow balloons 15-30 black balloons string
- Option 4** blindfold for each child

\*= Available in the optional **Kamp Kaboom kit**

# LESSON 1